



Instruction Manual



Genesis® G1

Hydro-Pneumatic Power Tool

Contents

Safety Instructions	4	General Assembly of Base Tool	
		General Assembly	26
		Parts List	27
Specifications		Priming	
Tool Specification	5	Oil Details	28
Tool Dimensions	5	Hyspin® VG32 Oil Safety Data	28
		Priming Kit	28
Intent of Use		Priming Procedure	29
Range of Fasteners	6	Fault Diagnosis	
Part Numbering	6	Symptom, Possible Cause and Remedy	30
Putting into Service			
Air Supply	7		
Operating Procedure	7		
Nose Assemblies			
Fitting Instructions	8		
Servicing Instructions	8		
Nose Tips	9 to 12		
Type 1	9		
Type 1A and Avseal® II	10		
Jaw Spreader Housing	11		
Type 2	12		
Type 3	12		
Accessories			
Stem Deflector	13		
Preparing the Base Tool for use with Stem Deflector	13		
Extension	13		
Swivel Heads	14		
Straight Swivel Head capability	14		
Preparing the Base Tool for Right-Angle and Straight	15		
Swivel Head Attachment			
Right-Angle Swivel Head capability	15		
Swivel Head Fitting Instructions	16		
Swivel Head Servicing Instructions	17		
Constant Components	17		
Servicing the Tool			
Daily / Weekly	18		
MolyLithium Grease EP 3753 Safety Data	18		
Molykote® 55m Grease Safety Data	19		
Molykote® 111 Grease Safety Data	19		
Service Kit	20		
Maintenance	20		
Nose Equipment	20		
Dismantling the Tool	21		
Head Assembly	21		
Pneumatic Piston Assembly	22		
Air Valve	22		
Rotary Valve	23		
Trigger	23		
Stop Plate Assembly (71213-03900)	24		

LIMITED WARRANTY

Avdel makes the limited warranty that its products will be free of defects in workmanship and materials which occur under normal operating conditions. This Limited Warranty is contingent upon: (1) the product being installed, maintained and operated in accordance with product literature and instructions, and (2) confirmation by Avdel of such defect, upon inspection and testing. Avdel makes the foregoing limited warranty for a period of twelve (12) months following Avdel's delivery of the product to the direct purchaser from Avdel. In the event of any breach of the foregoing warranty, the sole remedy shall be to return the defective Goods for replacement or refund for the purchase price at Avdel's option. THE FOREGOING EXPRESS LIMITED WARRANTY AND REMEDY ARE EXCLUSIVE AND ARE IN LIEU OF ALL OTHER WARRANTIES AND REMEDIES. ANY IMPLIED WARRANTY AS TO QUALITY, FITNESS FOR PURPOSE, OR MERCHANTABILITY ARE HEREBY SPECIFICALLY DISCLAIMED AND EXCLUDED BY AVDEL.

Avdel UK Limited policy is one of continuous product development and improvement and we reserve the right to change the specification of any product without prior notice.

Safety Instructions

This instruction manual must be read with particular attention to the following safety rules, by any person installing, operating, or servicing this tool.

- 1** Do not use outside the design intent.
- 2** Do not use equipment with this tool/machine other than that recommended and supplied by Avdel UK Limited.
- 3** Any modification undertaken by the customer to the tool/machine, nose assemblies, accessories or any equipment supplied by Avdel UK Limited. or their representatives, shall be the customer's entire responsibility. Avdel UK Limited. will be pleased to advise upon any proposed modification.
- 4** The tool/machine must be maintained in a safe working condition at all times and examined at regular intervals for damage and function by trained competent personnel. Any dismantling procedure shall be undertaken only by personnel trained in Avdel UK Limited. procedures. Do not dismantle this tool/machine without prior reference to the maintenance instructions. Please contact Avdel UK Limited. with your training requirements.
- 5** The tool/machine shall at all times be operated in accordance with relevant Health and Safety legislation. In the U.K. the "Health and Safety at Work etc. Act 1974" applies. Any question regarding the correct operation of the tool/machine and operator safety should be directed to Avdel UK Limited.
- 6** The precautions to be observed when using this tool/machine must be explained by the customer to all operators.
- 7** Always disconnect the air line from the tool/machine inlet before attempting to adjust, fit or remove a nose assembly.
- 8** Do not operate a tool/machine that is directed towards any person(s) or the operator.
- 9** Always adopt a firm footing or a stable position before operating the tool/machine.
- 10** Ensure that vent holes do not become blocked or covered.
- 11** The operating pressure shall not exceed 7 bar.
- 12** Do not operate the tool if it is not fitted with a complete nose assembly or swivel head unless specifically instructed otherwise.
- 13** Care shall be taken to ensure that spent stems are not allowed to create a hazard.
- 14** Vacuum Air MUST be turned off using the Trigger before removing the Stem Collector Bottle which Must be emptied when half full.
- 15** The Tool MUST NOT be operated with the Stem Collector Bottle removed.
- 16** If the tool is fitted with a stem deflector, it should be rotated until the aperture is facing away from the operator and other person(s) working in the vicinity.
- 17** When using the tool, the wearing of safety glasses is required both by the operator and others in the vicinity to protect against fastener ejection, should a fastener be placed 'in air'. We recommend wearing gloves if there are sharp edges or corners on the application.
- 18** Take care to avoid entanglement of loose clothes, ties, long hair, cleaning rags etc. in the moving parts of the tool which should be kept dry and clean for best possible grip.
- 19** When carrying the tool from place to place keep hands away from the trigger/lever to avoid inadvertent start up.
- 20** Excessive contact with hydraulic fluid oil should be avoided. To minimize the possibility of rashes, care should be taken to wash thoroughly.
- 21** C.O.S.H.H. data for all hydraulic oils and lubricants is available on request from your tool supplier.

Specifications

Air Pressure	Minimum - Maximum	5-7 bar
Free Air Volume Required	@ 5.5 bar	1.2 litres
Stroke	Minimum	14 mm
Pull Force	@ 5.5 bar	6.0 kN
Cycle Time	Approximately	0.9 seconds
Noise Level		75 dB(A)
Weight	Including nose equipment	1.7 kg
Vibration	Less than	2.5 m/s ²

Tool Dimensions

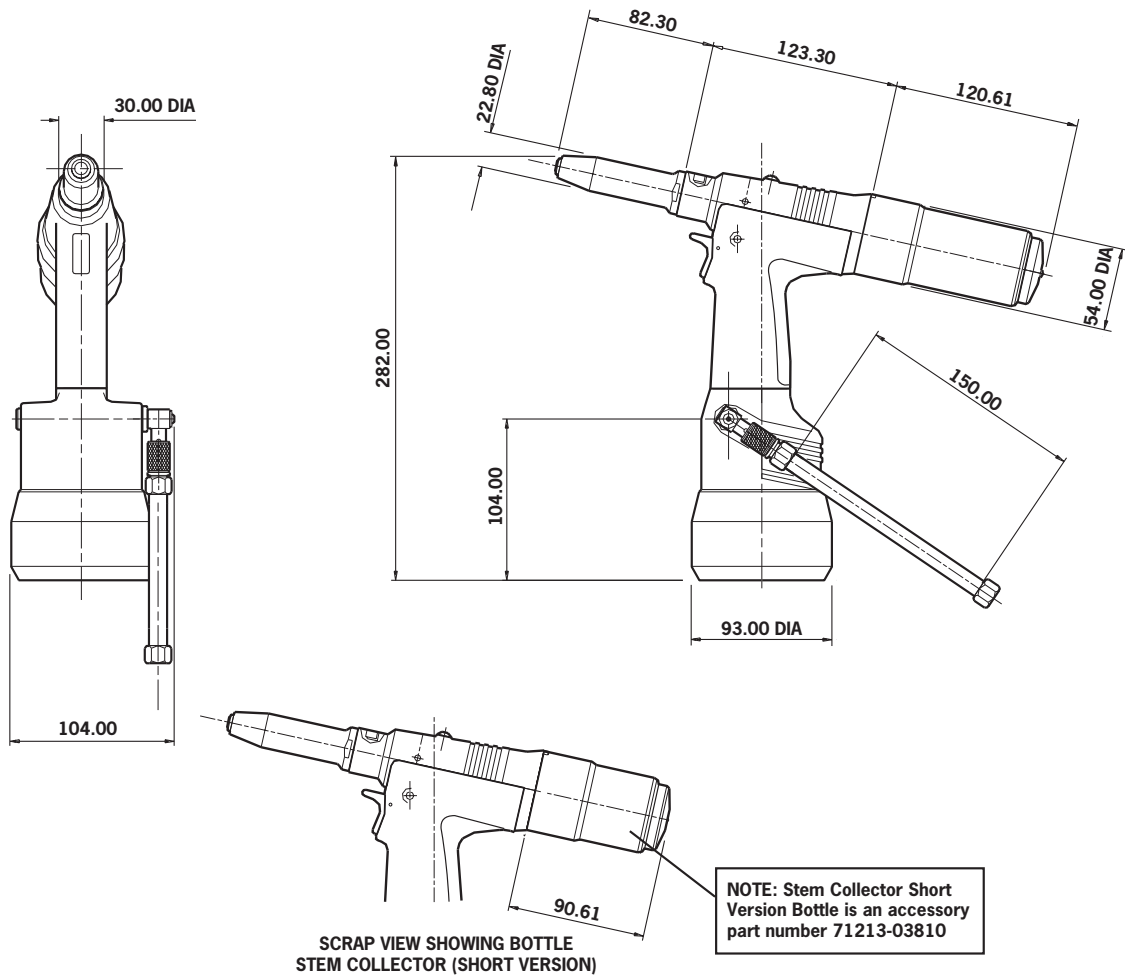

Dimensions in millimetres

Intent of Use

Range of Fasteners

nG1 is a hydro-pneumatic tool designed to place Avdel® breakstem fasteners at high speed making it ideal for batch or flow-line assembly in a wide variety of applications throughout all industries. It can place all fasteners listed opposite.

The tool features a vacuum system for fastener retention and trouble free collection of the spent stems regardless of tool orientation.

A complete tool is made up of three separate elements which will be supplied individually. See diagram below.

If you wish to place most of the fasteners in the table opposite, you can order the 71203-00039 complete tool comprising of:

- 71203-02000 base tool
- 71203-15000 nose assembly
- Nose tips 71210-05002 and 71210-16070. Fit nose tip as indicated page 8 or 9.

You can order the above two nose tips and nose assembly as a nose assembly kit part number 71203-15100.

- For some fasteners the base tool, nose assembly and nose tip must be ordered separately.

NOSE EQUIPMENT MUST BE FITTED AS DESCRIBED ON PAGE 8.

To assist with nose equipment maintenance spanner 07900-00849 is supplied with the base tool.

FASTENER NAME	FASTENER SIZE (MM / IN)									
	3	3.2	4.0	4.3	4.8	5	5.2	6	6.5	7
	-	1/8	5/32	-	3/16	-	-	-	-	-
AVEX®	●	●	●		●					
STAVEX®		●	●							
AVINOX®II		●								
AVIBULB®		●	●							
BULBEX®			●		●					
T-LOK®				●						
AVDEL® SR		●	●							
AVDEL®		●	●							
MBC®		●	●							
MBC/LC®		●	●							
AVSEAL®II			●			●				

Part Numbering

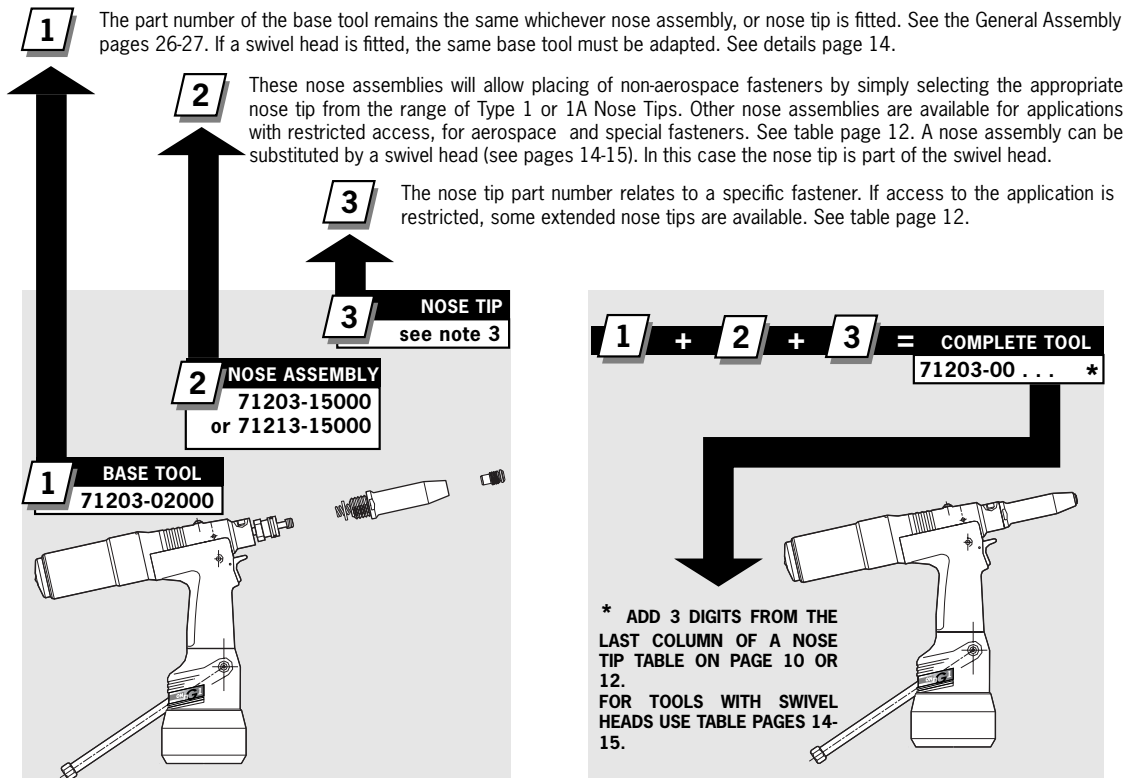

Putting into Service

Air Supply

All tools are operated with compressed air at an optimum pressure of 5.5 bar. We recommend the use of pressure regulators and filtering systems on the main air supply. These should be fitted within 3 metres of the tool (see diagram below) to ensure maximum tool life and minimum tool maintenance.

Air supply hoses should have a minimum effective working pressure rating of 150% of the maximum pressure produced in the system or 10 bar, whichever is the highest. Air hoses should be oil resistant, have an abrasion resistant exterior and should be armoured where operating conditions may result in hoses being damaged. All air hoses MUST have a minimum bore diameter of 6.4 millimetres or 1/4 inch.

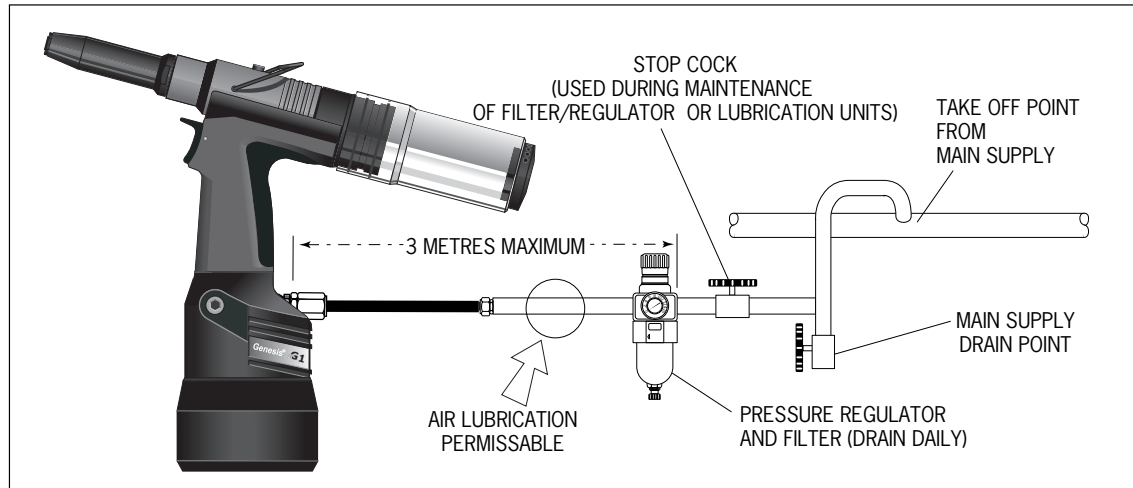

Operating Procedure

- Ensure that the correct nose assembly suitable for the fastener is fitted.
- Connect the tool to the air supply.
- Insert the fastener stem into the nose of the tool. If using a standard nose assembly, the fastener should remain held in by the vacuum system.
- Bring the tool with the fastener to the application so that the protruding fastener enters squarely into the hole of the application.
- Fully actuate the trigger. The tool cycle will broach the fastener and with standard nose assemblies the broken stem will be projected to the rear of the tool into the collector bottle.
- A partial rotation and pull movement removes the collector bottle. The Trigger should be lifted to cut-off the vacuum supply air prior to removing the collector bottle.
- To minimise air consumption, the trigger should be "lifted" to cut-off the vacuum air supply if the tool is not to be used for a period of time.

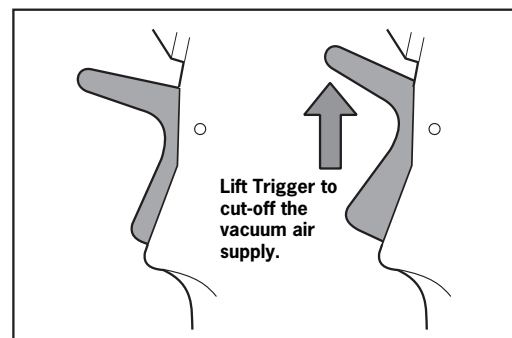
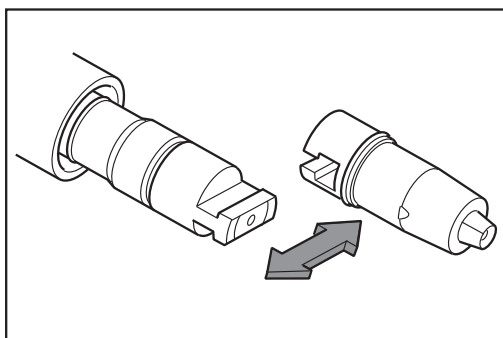
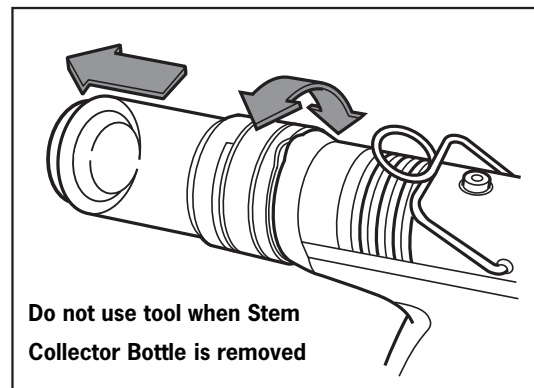

Nose Assemblies

Fitting Instructions

IMPORTANT

The air supply must be disconnected when fitting or removing nose assemblies.

Item numbers in bold refer to nose assembly components in all 5 Nose Tip tables (pages 9, 10 and 12).

- Lightly coat Jaws **4** with MolyLithium grease*.
- Drop Jaws **4** into Jaw Housing **3**.
- Insert Jaw Spreader **5** into Jaw Housing **3**.
- Locate Buffer **6** on Jaw Spreader **5**.
- Locate Spring **7** onto Jaw Spreader **5**.
- Insert Detent Sleeve **10** into Jaw Spreader Housing 'T' **9**. Not applicable to Type 2 and 3 Nose Assemblies.
- Fit Locking Ring **8** onto the Jaw Spreader Housing "T" **9**.
- For tools converted to nose assemblies Type 2 and 3, fit Locking Ring **8** onto the Jaw Spreader Housing 'T' **9** attached to the tool.
- Tighten Jaw Housing **3** and assembled components onto Jaw Spreader Housing 'T' **9**.
- Utilising the 'T' section profiles assemble Nose Assembly onto the tool piston via the Male 'T' Adaptor **40** - pages 26-27. Not applicable to Type 2 and 3 Nose Assemblies.
- Screw the nose tip into Nose Casing **1** and tighten with spanner*.
- Place Nose Casing **1** over Jaw Housing **3** and screw onto the tool, tightening with spanner*.

Servicing Instructions

Nose assemblies should be serviced at weekly intervals. You should hold some stock of all internal components of the nose assembly and nose tips as they will need regular replacement.

Use Spanner 07900-00849 (supplied with the tool) to assist when servicing the nose equipment.

- Remove the nose equipment using the reverse procedure to the 'Fitting Instructions'.
- Any worn or damaged part should be replaced.
- Clean and check wear on jaws.
- Ensure that the jaw spreader is not distorted.
- Check Spring **7** is not distorted.
- Assemble according to fitting instructions above.

* Item included in the Service Kit. For complete list see page 20.

Nose Assemblies

I M P O R T A N T

Nose assemblies do NOT include nose tips. Nose tips must be ordered separately.

A tool (except part number 71203-00039) must always be fitted with the correct nose assembly and nose tip for your fastener but if you wish to order a nose assembly or a nose tip separately, refer to the 'NOSE TIPS' tables below and pages 10 and 12.

If your application presents no access restriction use a Type '1' Nose Tip unless you are placing aerospace fasteners which requires a Type '3' Nose Tip.

Dimensions 'A' and 'B' below will help you assess the suitability of a particular nose tip.

You should also check that the dimensions of the nose casing will not restrict access to your application. If access is restricted Type '2' Nose Tips are available for some fasteners. Refer to the table page 12.

It is essential that nose assembly and nose tip are compatible with the fastener prior to operating the tool. If you have ordered a 71203-00039 complete tool, it is important that you check that the nose tip already fitted to the nose assembly is the correct one to place your fastener by sliding the fastener stem into the nose tip. No force should be required and play should be minimal.

Swivel heads are available as an alternative to nose assemblies when further reach is required. See pages 14-16 in the 'Accessories' section.

TYPE 1 NOSE TIPS

¹ In inches then in millimetres.

² Head forming nose tips for use with countersunk heads ONLY.

* Complete tool part number 71203-00039 does not only include the 71203-15000 nose assembly below but also the following two nose tips: 71210-05002 and 71210-16070 making up a nose assembly kit part number 71203-15100. Use the nose tip listed in the table.

* Items 3-11 available as cartridge assembly 71203-20320

Note:

Alternative spring 07498-04301 should be fitted if stem jamming occurs when installing small diameter fasteners.

NAME	FASTENER		MATERIAL	NOSE TIP (mm)			see below
	NAME	Ø ¹		PART N°	'A'	'B'	
AVEX®	1/8	3.2	Al Alloy	71210-05002	12.7	4.8	... 0 39*
	1/8	3.2	Steel	71210-16070	12.7	3.3	... 0 39*
	1/8	3.2	Al Alloy	07340-06401 ²	12.7	2.9	... 0 0 3
	-	3.0	Al Alloy	71210-05002	12.7	4.8	... 0 39*
	5/32	4.0	Al Alloy	71210-16070	12.7	3.3	... 0 39*
	5/32	4.0	Al Alloy	07340-06501 ²	12.7	3.3	... 0 0 9
BULBEX®	5/32	4.0	Al Alloy	71210-16070	12.7	3.3	... 0 39*
AVINOX® II	1/8	3.2	Stainless Steel	71210-16070	12.7	3.3	... 0 39*
AVIBULB®	1/8	3.2	Steel	71210-16070	12.7	3.3	... 0 39*
AVDEL® SR	1/8	3.2	Any	71210-05002	12.7	4.8	... 0 39*
	5/32	4.0	Any	71210-16070	12.7	3.3	... 0 39*
STAVEX®	1/8	3.2	Steel	71210-16070	12.7	3.3	... 0 39*
	1/8	3.2	Stainless Steel	71210-16070	12.7	3.3	... 0 39*
Q™ RIVET	1/8	3.2	Any	71210-05002	12.7	4.8	... 0 39*
N™ RIVET	3/32	2.4	Any	71200-16051	12.7	3.3	... 0 3 3

NOSE ASSEMBLY part n° 71203-15000 (+ 2nose tips above = 71203-15100)

ITEM	DESCRIPTION	PART N°
1	TAPERED NOSE CASING	71213-00350
2	'O' RING	07003-00067
3	JAW HOUSING TAPERED	71210-15902*
4	JAWS	71200-15001*
5	JAW SPREADER	07498-04502*
6	BUFFER	71210-05001*
7	(See Note:) SPRING	07500-00418*
8	LOCKING RING	07340-00327*
9	JAW SPREADER HOUSING 'T'	71210-20321*
10	DETENT SLEEVE	71210-20322*
11	'O' RING	07003-00277*

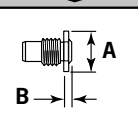
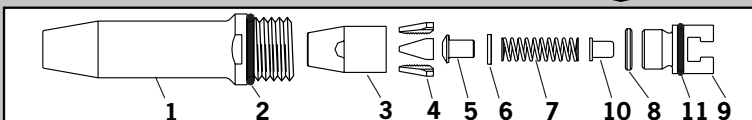

**COMPLETE TOOL
PART NUMBER :**
precede with 71203-00.
* See top left

Nose Assemblies

Nose Tips

TYPE 1A NOSE TIPS

NAME	FASTENER		MATERIAL	NOSE TIP (mm)			see below
	Ø ¹			PART N°	'A'	'B'	
AVEX®	5/32	4.0	Steel	07381-04701	12.7	2.8	... 020
	3/16	4.8	Al Alloy	07381-04701	12.7	2.8	... 020
	3/16	4.8	Al Alloy	07340-04800	19.0	3.3	... 016
	3/16	4.8	Al Alloy	07340-06601 ²	12.7	4.1	... 015
BULBEX®	3/16	4.8	Al Alloy	07381-04701	12.7	2.8	... 020
T-LOK®	-	4.3	Steel	07340-06201	12.7	3.3	... 120
AVIBULB®	5/32	4.0	Steel	07381-04701	12.7	2.8	... 020
STAVEX®	5/32	4.0	Steel	07381-04701	12.7	2.8	... 020
	5/32	4.0	Stainless Steel	07381-04701	12.7	2.8	... 020
Q™ RIVET	5/32	4.0	Any	07340-06201	12.7	3.3	... 120

¹ In inches then in millimetres.
² Head forming nose tips for use with countersunk heads ONLY.

* Items 3-11 available as cartridge assembly 71213-20320

NOSE ASSEMBLY part n° 71213-15000

ITEM	DESCRIPTION	PART N°
1	TAPERED NOSE CASING	71213-00350
2	'O' RING	07003-00067
3	JAW HOUSING TAPERED	71210-15902*
4	JAWS	71210-15001*
5	JAW SPREADER	07498-04502*
6	BUFFER	71210-05001*
7	SPRING	07500-00418*
8	LOCKING RING	07340-00327*
9	JAW SPREADER HOUSING 'T'	71210-20321*
10	DETENT SLEEVE	71210-20322*
11	'O' RING	07003-00277*

**COMPLETE TOOL
PART NUMBER :**
precede with 71203-00.

AVSEAL® II NOSE TIPS

NAME	FASTENER		MATERIAL	NOSE TIP (mm)			see below	
	Ø ¹			PART N°	'A'	'B'		
AVSEAL® II	5/32	4.0	Standard Al. Alloy - Flush Nose Tip	71213-16100	71210-16102	12.7	2.5	... 401
	5/32	4.0	Standard Al. Alloy - 2mm Extended Nose Tip	71213-16100	71210-16106	12.7	5.4	... 402
	5/32	4.0	Standard Al. Alloy - 8mm Extended Nose Tip	71213-16100	71210-16110	12.7	11.4	... 403
	-	5.0	Standard Al. Alloy - Flush Nose Tip	71213-16100	71210-16103	12.7	2.5	... 404
	-	5.0	Standard Al. Alloy - 2mm Extended Nose Tip	71213-16100	71210-16107	12.7	5.4	... 405
	-	5.0	Standard Al. Alloy - 8mm Extended Nose Tip	71213-16100	71210-16111	12.7	11.4	... 406

¹ In inches then in millimetres.

NOSE ASSEMBLY part n° 71213-16100

ITEM	DESCRIPTION	PART N°
1	TAPERED NOSE CASING	71213-00350
2	'O' RING	07003-00067
3	JAW HOUSING - TAPERED	71210-15902 *
4	JAW	71210-16101 *
5	JAW SPREADER	07498-04502 *
6	BUFFER	71210-05001 *
7	SPRING	07500-00418 *
8	LOCKING RING	07340-00327 *
9	JAW SPREADER HOUSING 'T'	71210-20321 *
10	DETENT SLEEVE	71210-20322 *
11	'O' RING	07003-00277 *

**COMPLETE TOOL
PART NUMBER :**
precede with 71203-00.

* Items 3-11 available as cartridge assembly 71213-16320

10 **Avdel®**
An Acument™ Global Technologies Company

Nose Assemblies

Nose Tips

Jaw Spreader Housing

To fit Nose Tips Type 2/3 or Nose Extension, the Male 'T' Adaptor **40** must be replaced with Jaw Spreader Housing **9***.

- Loosen Locknut **39** using 16mm AF Spanner.
- Unscrew and remove Male 'T' Adaptor **40** together with 'O' Ring **11**.

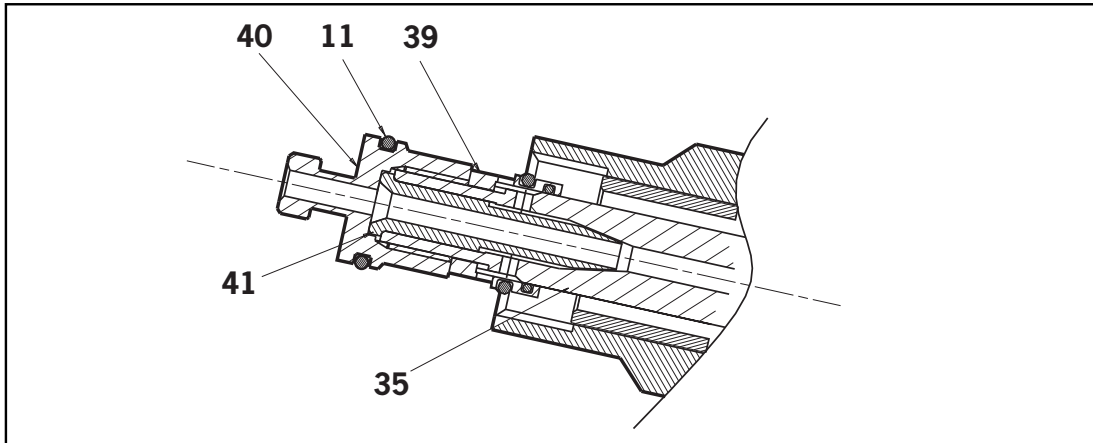

- Fit Jaw Spreader Housing **9*** (71210-02101) together with 'O' Ring **10*** or **11*** (Jaw Spreader Housing **9*** and 'O' Ring **10*** or **11*** are supplied with Type 2 and 3 Nose Assemblies)
- The Jaw Spreader Housing **9*** must be tightened onto Head Piston **35** trapping Vacuum Sleeve **41** finally tighten Locknut **39** against Jaw Spreader Housing **9***.

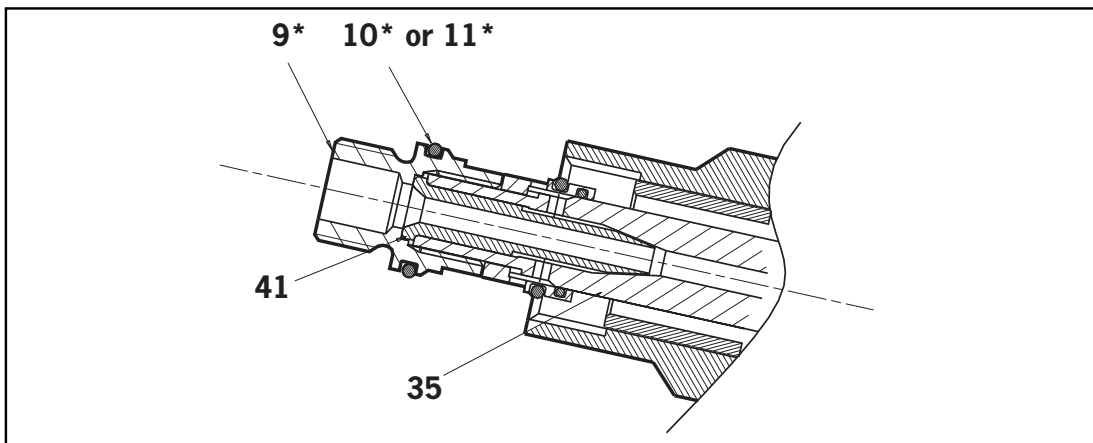

Items **9*** and **10*** or **11*** refer to illustrations on pages 9, 10 and 12.

For other items refer to the general assembly drawing and parts list on pages 26 and 27.

Nose Assemblies

Nose Tips

To fit Nose Tips Type 2 or 3 remove Male 'T' Adaptor **40** and replace with Jaw Spreader Housing **9*** and 'O' Ring **10***.

TYPE 2 NOSE TIPS

NOSE ASSEMBLY part n° 71210-15200

ITEM	DESCRIPTION	PART N°
1	NOSE CASING	07340-02804
2	'O' RING	07003-00067
3	JAW HOUSING	07340-00304
4	JAWS	71210-15001
5	JAW SPREADER	07498-04502
6	BUFFER	71210-05001
7	SPRING	07500-00418
8	LOCKING RING	07340-00327
9	JAW SPREADER HOUSING	71210-02101
10	'O' RING	07003-00277

NAME	FASTENER		NOSE TIP (mm)			see below
	Ø ¹	MATERIAL	PART N°	'A'	'B'	
AVEX®	1/8 : 3.2	Aluminium Alloy	07340-02805	9.5	12.95	... 0 0 2
	1/8 : 3.2	Steel	07340-02806	9.5	11.4	... 0 0 8
	5/32 : 4.0	Aluminium Alloy	07340-02806	9.5	11.4	... 0 0 8
	5/32 : 4.0	Steel	07340-02807	12.7	10.0	... 0 1 4
BULBEX®	3/16 : 4.8	Aluminium Alloy	07340-02807	12.7	10.0	... 0 1 4
	5/32 : 4.0	Aluminium Alloy	07340-02806	9.5	11.4	... 0 0 8
T-LOK®	- : 4.3	Steel	07241-07101	12.7	10.0	... 1 2 1
STAVEX®	1/8 : 3.2	Steel	07340-02806	9.5	11.4	... 0 0 8
	5/32 : 4.0	Steel	07340-02807	12.7	10.0	... 0 1 4
	1/8 : 3.2	Stainless Steel	07340-02806	9.5	11.4	... 0 0 8
AVIBULB®	5/32 : 4.0	Stainless Steel	07340-02807	12.7	10.0	... 0 1 4
	1/8 : 3.2	Steel	07340-02806	9.5	11.4	... 0 0 8
	5/32 : 3.2	Steel	07340-02807	12.7	10.0	... 0 1 4

¹ In inches then in millimetres.

TYPE 2 NOSE TIPS ARE EXTENDED TO ALLOW ACCESS INTO APPLICATIONS WHERE TYPE 1 NOSE TIPS WILL NOT REACH.

COMPLETE TOOL PART NUMBER :
precede with
71203-00

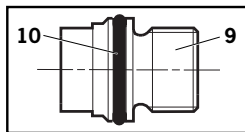

Remove Male 'T' Adaptor **40** from the Tool (see page 11) and replace with Jaw Spreader Housing **9*** (71210-02101) and 'O' Ring **10***.

TYPE 3 NOSE TIPS

NOSE ASSEMBLY part n° 71210-15300

ITEM	DESCRIPTION	PART N°
1	NOSE CASING	07344-02001
2	'O' RING	07003-00067
3	JAW HOUSING	07340-00304
4	JAWS	71210-15001
5	JAW SPREADER	07498-04502
6	BUFFER	71210-05001
7	SPRING	07500-00418
8	LOCKING RING	07340-00327
9	JAW SPREADER HOUSING	71210-02101
10	'O' RING	07003-00277

TYPE 3 NOSE TIPS ARE SPECIFICALLY FOR THE AEROSPACE FASTENERS LISTED BELOW.

NAME	FASTENER		NOSE TIP (mm)			see below
	Ø ¹	MATERIAL	PART N°	'A'	'B'	
AVDEL®	1/8 : 3.2	Al Alloy	71210-16030	12.7	2.5	... 2 8 3
	1/8 : 3.2	Al Alloy O	71210-16031	12.7	2.5	... 2 8 4
	1/8 : 3.2	Stainless Steel	71210-16032	12.7	3.3	... 2 8 5
	5/32 : 4.0	Al Alloy	71210-16033	12.7	2.5	... 2 8 8
	5/32 : 4.0	Al Alloy O	71210-16034	12.7	2.5	... 2 8 9
MBC®	5/32 : 4.0	Stainless Steel	71210-16035	12.7	3.3	... 2 9 0
	1/8 : 3.2	Any	07340-06701	12.7	4.8	... 3 0 0
MBC L/C®	5/32 : 4.0	Any	07340-06801	12.7	5.0	... 3 0 5
	1/8 : 3.2	Any	07344-04701	12.7	4.6	... 3 2 0
	5/32 : 4.0	Any	07344-04701	12.7	4.6	... 3 2 0

¹ In inches then in millimetres. **O** Oversize

TYPE 3 NOSE TIPS ARE SPECIFICALLY FOR THE AEROSPACE FASTENERS LISTED BELOW.

COMPLETE TOOL PART NUMBER :
precede with
71203-00

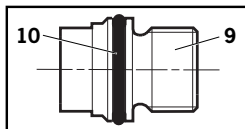

Remove Male 'T' Adaptor **40** from the Tool (see page 11) and replace with Jaw Spreader Housing **9*** (71210-02101) and 'O' Ring **10***.

9* and **10*** refer to the illustrations on this page. Item **40** refer to pages 26 and 27.

Accessories

Stem Deflector

The stem deflector is a very simple alternative to the standard stem collector and allows access in restricted areas. To replace the stem collector with the stem deflector proceed as follows:

Preparing the Base Tool for use with Stem Deflector

The air line must be disconnected before any servicing or dismantling.

'Sealed' Nut 71213-02200 replaces Locknut **39** (to cut-off air supply to Vacuum System) as follows:

- Loosen Locknut **39** using 16mm AF Spanner.
- Unscrew and remove both Male 'T' Adaptor **40** and Locknut **39**.
- Replace Locknut **39** with 'Sealed Nut' 71213-02200, screw 'Sealed Nut' onto Head Piston **35** to disable Vacuum System.
- Male 'T' Adaptor **40** must be tightened onto Head Piston **35**, finally tightening 'Sealed Nut' against it.
- Remove the Stop Plate Assembly (page 24) by unscrewing Screws **63** (2off).

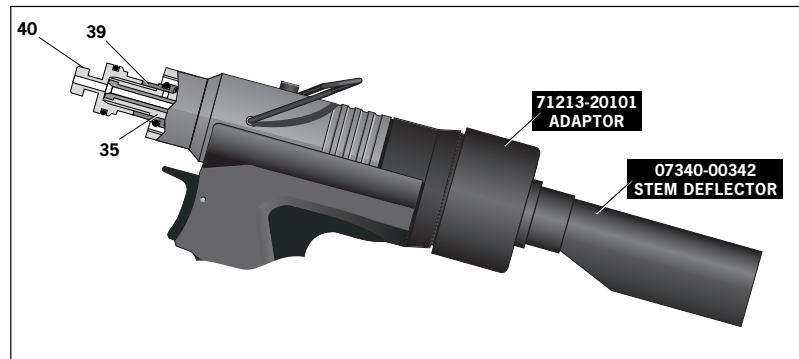

- Fit Stem Deflector (07340-00342) into Adaptor (71213-20101).
- Push the assembled Stem Deflector and Adaptor over Bottle Adaptor Assembly **31** and align with the cut-out feature.

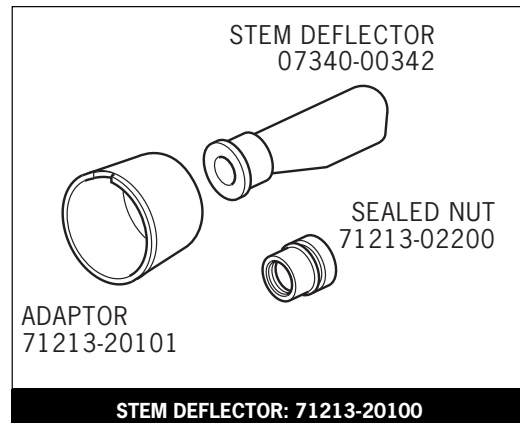

Extension

Fitted between the tool and the nose assembly the extension allows access into deep channels.

- The Tool must be fitted with Jaw Spreader Housing **9*** (71210-02101) and 'O' Ring before extension (71210-20300). See page 11.
- To fit the extension, remove any nose assembly components.
- Screw the Inner extension to Jaw Spreader Housing **9***.
- Screw the Outer extension onto Head Assembly **50**.
- Fit the nose assembly onto the extension.

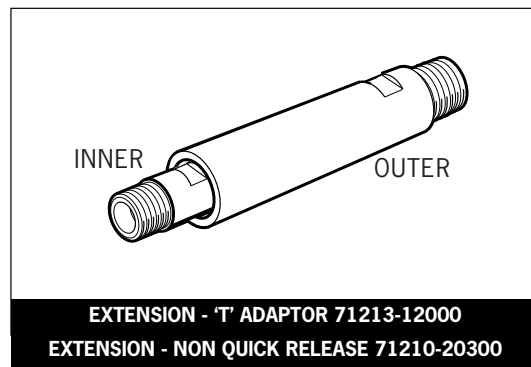

Item numbers in **bold** refer to the general assembly drawing and parts list on pages 26 and 27.

9* refers to illustrations on pages 11 and 12.

Accessories

Swivel Heads

Instead of a nose assembly, a swivel head can be fitted to a base tool. It allows 360° rotation of the tool about the nose tip and allows access into many applications otherwise too restrictive. There are two types of swivel heads: the straight swivel head with the nose tip slightly offset from the centre line of the tool head and the right-angle swivel head with the nose tip on a perpendicular axis to the head of the tool. See drawings below for dimensions and pages 15-16 for detail.

IMPORTANT

PRIOR to fitting a swivel head, the base tool must be adapted. See Preparing the Base Tool opposite. In contrast to nose assemblies part numbers of swivel heads do INCLUDE a nose tip as shown below.

Swivel heads are supplied separately for fitting to a base tool forming a complete tool. See table below for part numbers. Jaws and nose tips vary depending on the fastener to be placed but all other components remain the same within each type of swivel head. See the 'capability' tables below and page 15. For the 'Constant Components' table see page 17.

'A' and 'B' dimensions will help you assess the accessibility of your application.

STRAIGHT SWIVEL HEAD capability

NAME	FASTENER		SWIVEL HEAD PART N°	NOSE TIP (mm)		JAWS PART N°	see below	
	Ø ¹	MATERIAL		'A'	'B'			
AVEX®	1/8 : 3.2	Al Alloy	07345-03000	07345-03600	7.87	3.81	07340-00213 ... 001	
	1/8 : 3.2	Steel	07345-03100	07345-03700	7.87	3.81	07340-00213 ... 004	
	5/32 : 4.0	Al Alloy	07345-03100	07345-03700	7.87	3.81	07340-00213 ... 004	
	5/32 : 4.0	Steel	07345-03200	07345-03800	7.87	3.81	07490-04602 ... 010	
	3/16 : 4.8	Al Alloy	07345-03200	07345-03800	7.87	3.81	07490-04602 ... 010	
BULBEX®	5/32 : 4.0	Al Alloy	07345-03100	07345-03700	7.87	3.81	07340-00213 ... 004	
	3/16 : 4.8	Al Alloy	07345-03200	07345-03800	7.87	3.81	07490-04602 ... 010	
AVINOX®II	1/8 : 3.2	Stainless Steel	07345-03100	07345-03700	7.87	3.81	07340-00213 ... 004	
	5/32 : 4.0	Stainless Steel	07345-03200	07345-03800	7.87	3.81	07490-04602 ... 010	
STAVEX®	1/8 : 3.2	Steel	07345-03100	07345-03700	7.87	3.81	07340-00213 ... 004	
	5/32 : 3.2	Steel	07345-03200	07345-03800	7.87	3.81	07490-04602 ... 010	
	1/8 : 4.0	Stainless Steel	07345-03100	07345-03700	7.87	3.81	07340-00213 ... 004	
	5/32 : 4.0	Stainless Steel	07345-03200	07345-03800	7.87	3.81	07490-04602 ... 010	
AVSEAL®II	-	4	Al Alloy	07494-06000	07494-06001	6.35	1.95	07340-00213 ... 160
	-	4	Al Alloy	07494-06600	07494-06601 ²	6.35	4.11	07340-00213 ... 180
	-	5	Al Alloy	07494-06100	07494-06101	7.62	2.00	07340-00213 ... 161
	-	5	Al Alloy	07494-06700	07494-06701 ²	7.62	4.11	07340-00213 ... 181
AVDEL®	1/8 : 3.2	Al Alloy	07345-03300	07345-03301	5.08	1.17	07340-00229 ... 283	
	1/8 : 3.2	Al Alloy O	07494-03600	07494-03601	5.08	1.17	07340-00229 ... 284	
	1/8 : 3.2	Stainless Steel	07494-03000	07494-03011	5.08	3.81	07340-00213 ... 285	
	5/32 : 4.0	Al Alloy	07345-03400	07345-03401	6.6	0.84	07340-00229 ... 288	
	5/32 : 4.0	Al Alloy O	07494-03700	07494-03701	6.6	0.84	07340-00229 ... 289	
MBC®	1/8 : 3.2	Al Alloy	07345-04000	07165-00701	4.75	1.9	07340-00229 ... 300	
	5/32 : 4.0	Al Alloy	07345-04100	07165-00702	6.35	2.36	07340-00229 ... 305	
MBC L/C®	1/8 : 3.2	Al Alloy	07345-04700	07345-04701	7.87	2.03	07340-00229 ... 320	
	5/32 : 4.0	Al Alloy	07345-04700	07345-04701	7.87	2.03	07340-00229 ... 320	
	5/32 : 4.0	Al Alloy O	07345-04800	07345-04701	7.87	2.03	07498-04401 ... 327	

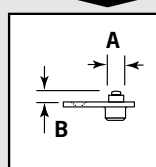
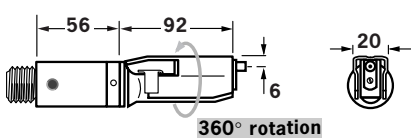

COMPLETE TOOL PART NUMBER :
precede with 71203-30
(the stop nut and safety cap are included)

IMPORTANT: by opposition to complete tools with nose assemblies, those fitted with swivel heads include the nose tip as a part of the head.

¹ In inches then in millimetres.

² Long nose tip for deep placing.

O Oversize

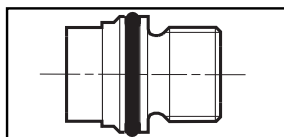

Remove Male 'T' Adaptor **40** from the Tool (see pages 11 and 15) and replace with Jaw Spreader Housing (71210-02101).

Accessories

Preparing the Base Tool for Right-Angle and Straight Swivel Head Attachment

- Disconnect the air supply.
- Remove any nose assembly items.
- Remove Stem Collector Bottle Assembly **24** (71213-03800).
- Replace assembly **24** with Safety Cap (71213-20201)
- Unscrew Male 'T' Adaptor **40** and remove with 'O' Ring **11**, Locknut **39**, 'O' Rings **18** and **14**, and Seal Housing **48**. Do not refit these items.
- Screw Stop Nut (71213-20200) onto the front of Head Piston **35** as far as it will go by hand.
- Fit Jaw Spreader Housing (71210-02101) and 'O' Ring **11**, tighten onto Head Piston **35**, finally tighten Stop Nut against Jaw Spreader Housing.

The tool is now ready to be fitted with a swivel head. Instructions page 16.

Item numbers in **bold** refer to the general assembly drawing and parts list on pages 26-27.

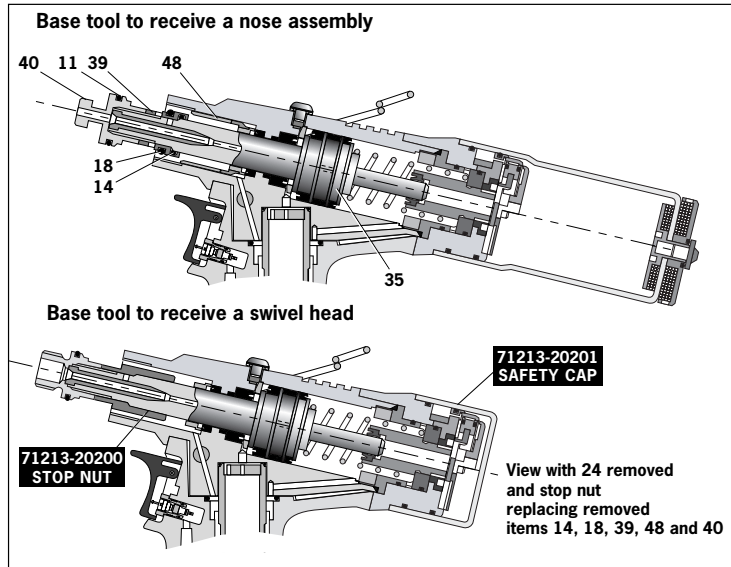

RIGHT-ANGLE SWIVEL HEAD capability

NAME	FASTENER		SWIVEL HEAD PART N°	NOSE TIP (mm)		JAWS PART N°	see below
	Ø ¹	MATERIAL		PART N°	'A'		
AVEX®	1/8	3.2 Aluminium Alloy	07346-03000	07345-03600	7.87	3.81	07340-00213 ... 001
	1/8	3.2 Steel	07346-03100	07345-03700	7.87	3.81	07340-00213 ... 004
	5/32	4.0 Aluminium Alloy	07346-03100	07345-03700	7.87	3.81	07340-00213 ... 004
	5/32	4.0 Steel	07346-03200	07345-03800	7.87	3.81	07490-04602 ... 010
	3/16	4.8 Aluminium Alloy	07346-03200	07345-03800	7.87	3.81	07490-04602 ... 010
BULBEX®	5/32	4.0 Aluminium Alloy	07346-03100	07345-03700	7.87	3.81	07340-00213 ... 004
	3/16	4.8 Aluminium Alloy	07346-03200	07345-03800	7.87	3.81	07490-04602 ... 010
AVINOX® II	1/8	3.2 Stainless Steel	07346-03100	07345-03700	7.87	3.81	07340-00213 ... 004
	5/32	4.0 Stainless Steel	07346-03200	07345-03800	7.87	3.81	07490-04602 ... 010
AVSEAL® II	-	4 Aluminium Alloy	71213-04000	71213-16401	6.35	1.95	07340-00213 ... 160
	-	4 Aluminium Alloy	71213-04700	71213-16402 ²	6.35	4.11	07340-00213 ... 180
	-	5 Aluminium Alloy	71213-04100	71213-16403	7.62	2.00	07340-00213 ... 161
	-	5 Aluminium Alloy	71213-04800	71213-16404 ²	7.62	4.11	07340-00213 ... 181
STAVEX®	1/8	3.2 Steel	07346-03100	07345-03700	7.87	3.81	07340-00213 ... 004
	5/32	4.0 Steel	07346-03200	07345-03800	7.87	3.81	07490-04602 ... 010
	1/8	3.2 Stainless Steel	07346-03100	07345-03700	7.87	3.81	07340-00213 ... 004
	5/32	4.0 Stainless Steel	07346-03200	07345-03800	7.87	3.81	07490-04602 ... 010
AVDEL®	1/8	3.2 Aluminium Alloy	07346-03300	07345-03301	5.08	1.17	07340-00229 ... 283
	1/8	3.2 Aluminium Alloy O	07495-03600	07494-03601	5.08	1.17	07340-00229 ... 284
	1/8	3.2 Stainless Steel	07495-03000	07494-03011	5.08	3.81	07340-00213 ... 285
	5/32	4.0 Aluminium Alloy	07346-03400	07345-03401	6.6	0.84	07340-00229 ... 288
	5/32	4.0 Aluminium Alloy O	07495-03700	07494-03701	6.6	0.84	07340-00229 ... 289
MBC®	1/8	3.2 Aluminium Alloy	07346-04000	07165-00701	4.75	1.9	07340-00229 ... 300
	5/32	4.0 Aluminium Alloy	07346-04100	07165-00702	6.35	2.36	07340-00229 ... 305
MBC L/C®	1/8	3.2 Aluminium Alloy	07346-04500	07345-04701	7.87	2.03	07340-00229 ... 320
	5/32	4.0 Aluminium Alloy	07346-04500	07345-04701	7.87	2.03	07340-00229 ... 320
	5/32	4.0 Aluminium Alloy O	07346-04600	07345-04701	7.87	2.03	07498-04401 ... 327

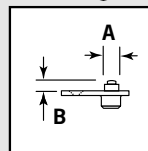
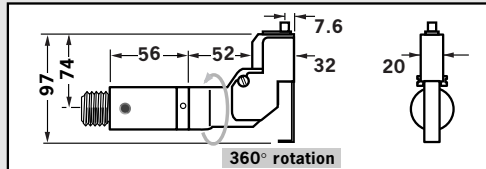

COMPLETE TOOL PART NUMBER :
precede with 71203-40
(the stop nut and safety cap are included)

IMPORTANT: in contrast to complete tools with nose assemblies, those fitted with swivel heads include the nose tip as a part of the head.

¹ In inches then in millimetres. ² Long nose tip for deep placing. **O** Oversize

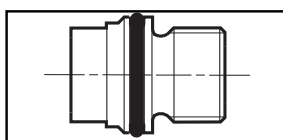

Remove Male 'T' **40** Adaptor from the Tool and replace with Jaw Spreader Housing (71210-02101) See 'Preparing the Base Tool' above and page 11.

Accessories

The fitting and servicing procedures for both types of head are almost identical. Differences are clearly indicated.

IMPORTANT

**PRIOR to fitting a swivel head, the base tool must be adapted. See Preparing the Base Tool page 15.
The air supply must be disconnected when fitting or removing swivel heads.**

Swivel Head Fitting Instructions

The following procedure will allow you to assemble and fit either of the swivel heads to the tool. If you order a complete swivel head rather than individual components, you will only need to start at stage 'L'.

All moving parts should be lubricated. Unless stated otherwise use MolyLithium grease (details page 18).

When on grey tint, instructions refer only to the right-angle swivel head. Item numbers in **bold** refer to illustrations below.

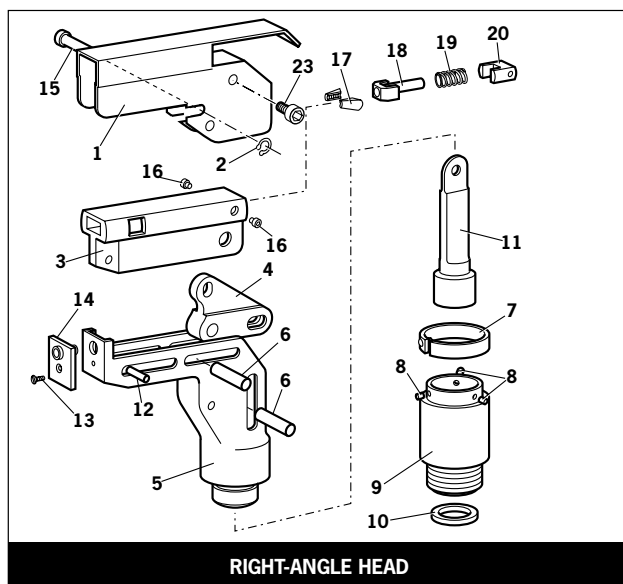
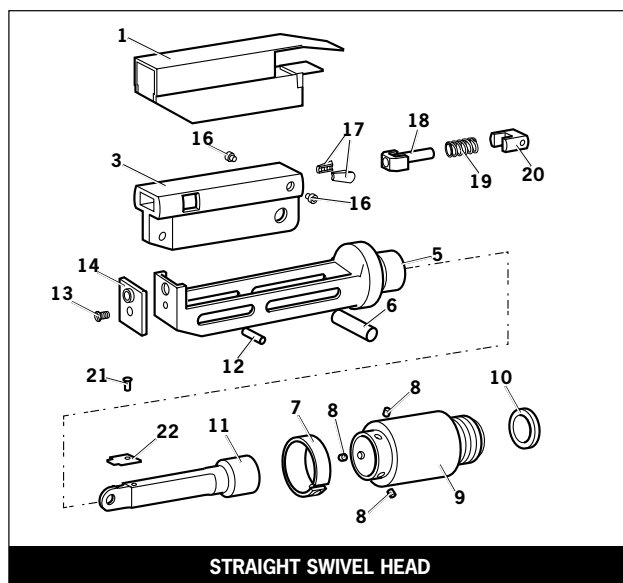

- A** Fit Locking Ring **10** over Jaw Spreader Housing **9*** (71210-02101). *See pages 11 and 12.
- B** Coat Screw **13** with thread locking adhesive and use to secure Nose Tip **14** onto Body **5**.
- C** Lightly lubricate items **17**, **18**, **19**, **20** and insert into Jaw Carrier **3** as shown. Secure with Screws **16**.
- D** Position Lever **4** into Body **5** and hold in place with pin **15** through the hole of Body **5** (not a slot).
- E** Lubricate the sides of the Jaw Carrier Assembly and insert into Body **5**.
- F** Lubricate Rollers **8** and ENSURE that they will freely rotate in the holes of Adaptor **9**. If necessary ream the holes.
- G** Position Spring Clip **7** over Adaptor **9** past the holes for the rollers and rotate until the locating peg is aligned with the corresponding hole in Adaptor **9** (smallest hole).
- H** Fit Adaptor **9** over the end of Body **5** and drop Rollers **8** into place. Push Spring Clip **7** over Rollers **8**.
- I** Insert Spindle **11** through Adaptor **9** into Jaw Carrier **3** until the hole lines up with slot in Body **5**. Temporarily hold in place with Pin **6**.
- J** Insert Pin **12** through the front slot of Body **5** into Jaw Carrier **3**.
- K** Hold the assembly vertical to prevent all pins dropping out and slide the jaw carrier assembly back and forth a few times to ensure free movement. Go to **M**.
- L** Remove Screws **23** (4 off) and Guard **1**. On a straight swivel head also remove Screw **21** and Platform **22**.
- M** Push Pin(s) **6** out and let Spindle **11** drop out. Screw Spindle **11** onto the Jaw Spreader Housing of the tool, leaving the small screw fixing hole uppermost for straight swivel. Tighten gently with a tommy bar.
- N** Screw the assembly over Spindle **11** onto the tool handle. Replace Pin(s) **6**.
- O** On straight swivel heads attach Platform **22** onto the top of the Spindle **11** with Screw **21**. Deburr the back end of Platform **22** so that it cannot catch on Guard **1**.
- P** Snap Guard **1** over the assembly, align screw holes in guard with tapped holes in body assembly.
- Q** Insert Pivot Pin **15** through slots in guard and hole in body. Fit Circlip **2** onto pivot pin so that the circlip seats in groove provided.
- R** Coat the thread of Screws **23** (4 off) with thread locking adhesive and screw into body assembly securing guard to body assembly.

9* refers to illustrations on pages 11 and 12.

Accessories

Swivel Head Servicing Instructions

Swivel heads should be serviced at weekly intervals.

- Remove the complete head using the reverse procedure to the 'Fitting instructions' omitting step 'L'.
- If Guard **1** is at all damaged it must be replaced by a new one.
- Any worn or damaged parts should be replaced.
- Pay particular attention to jaw carrier items in the upper illustration opposite as follows:
Check wear on Jaws **17**.
Check that Jaw Spreader Tube **18** is not distorted.
Check that Spring **19** is neither broken or distorted.
Check that Spring Guide **20** is not damaged.
- Check that Spring clip **7** is not distorted. When removing Spring Clip **7**, use two screwdrivers as shown in the lower illustration opposite.
- Check for excessive wear on slots of Body **5**.
- Assemble according to fitting instructions.

Item numbers in bold refer to Swivel Head illustrations on this page. Guard **1** refers to illustration on page 16.

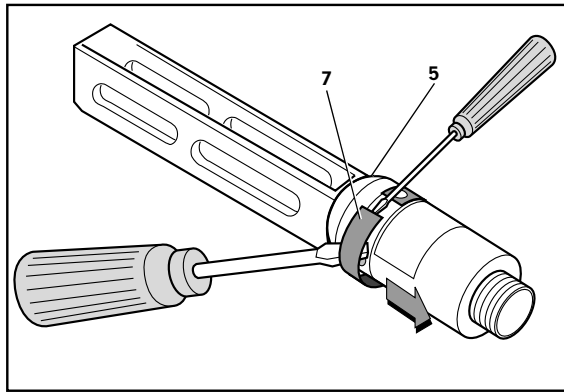
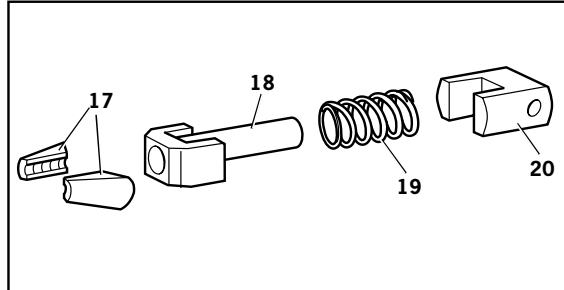

While nose tips and jaws will vary for each swivel head, other components remain constant within each type of head. See table below. For nose tips and jaws part numbers see within the table on pages 14 and 15.

CONSTANT COMPONENTS			
ITEM	DESCRIPTION	STRAIGHT SWIVEL	RIGHT-ANGLE SWIVEL
1	GUARD	07494-05000	07495-03003
2	CIRCLIP	-	07004-00105
3	JAW CARRIER	07494-03026	07494-03026
4	LEVER	-	07495-03004
5	BODY	07494-03015	07495-03002
6	PIVOT PIN	07343-02207	07343-02207
7	SPRING CLIP	07495-03900	07495-03900
8	ROLLER	07007-00039	07007-00039
9	ADAPTOR	07345-03001	07345-03001
10	LOCKING RING	07345-03003	07345-03003
11	SPINDLE	07345-03002	07345-03002
12	DOWEL PIN	07007-00038	07007-00038
13	SCREW	07342-02207	07342-02207
15	PIVOT PIN	-	07495-03005
16	SCREW	07494-03028	07494-03028
18	JAW SPREADER	07346-03101	07346-03101
19	SPRING	07165-00305	07165-00305
20	SPRING GUIDE	07494-03027	07494-03027
21	SCREW	07001-00368	-
22	PLATFORM	07345-00401	-
23	SCREW	-	07210-00804

Servicing the Tool

I M P O R T A N T

Read Safety Instructions on page 4.

**The employer is responsible for ensuring that tool maintenance instructions are given to the appropriate personnel.
The operator should not be involved in maintenance or repair of the tool unless properly trained.
The tool shall be examined regularly for damage and malfunction.**

Daily

- Daily, before use or when first putting the tool into service, pour a few drops of clean, light lubricating oil into the air inlet of the tool if no lubricator is fitted on air supply. If the tool is in continuous use, the air hose should be disconnected from the main air supply and the tool lubricated every two to three hours.
- Check for air leaks. If damaged, hoses and couplings should be replaced.
- If there is no filter on the pressure regulator, bleed the air line to clear it of accumulated dirt or water before connecting the air hose to the tool. If there is a filter, drain it.
- Check that the nose assembly or swivel head is correct for the fastener to be placed.
- Check the stroke of the tool meets the minimum specification (page 5). The last step of the Priming Procedure on page 29 explains how to measure the stroke.
- Either a stem collector or a stem deflector must be fitted to the tool unless using a swivel head is fitted.
- Check that Base Cover **30** is fully tightened onto Body **29**.
- Stem Collector Bottle: 'O' Rings **19** and **27** to be checked for wear, cleaned and lubricated with Molykote® 55m.

Weekly

- Dismantle and clean the nose assembly with special attention to the jaws. Lubricate with MolyLithium grease before assembling.
- Check for oil leaks and air leaks in the air supply hose and fittings.

MolyLithium Grease EP 3753 Safety Data

Grease can be ordered as a single item, the part number is shown in the Service Kit page 20.

First Aid

SKIN:

As the grease is completely water resistant it is best removed with an approved emulsifying skin cleaner.

INGESTION:

Ensure the individual drinks 30ml Milk of Magnesia, preferably in a cup of milk.

EYES:

Irritant but not harmful. Irrigate with water and seek medical attention.

Fire

FLASH POINT: Above 220°C.

Not classified as flammable.

Suitable extinguishing media: CO₂, Halon or water spray if applied by an experienced operator.

Environment

Scrape up for incineration or disposal on approved site.

Handling

Use barrier cream or oil resistant gloves

Storage

Away from heat and oxidising agent.

Item numbers in **bold** refer to the general assembly drawing and parts list on pages 26-27.

Servicing the Tool

Molykote® 55m Grease Safety Data

First Aid

SKIN:

Flush with water. Wipe off.

INGESTION:

No first aid should be needed.

EYES:

Flush with water.

Fire

FLASH POINT: Above 101.1°C. (closed cup)

Explosive Properties: No

Suitable Extinguishing Media: Carbon Dioxide Foam, Dry Powder or fine water spray.

Water can be used to cool fire exposed containers.

Environment

Do not allow large quantities to enter drains or surface waters.

Methods for cleaning up: Scrape up and place in suitable container fitted with a lid. The spilled product produces an extremely slippery surface.

Harmful to aquatic organisms and may cause long-term adverse effects in the aquatic environment. However, due to the physical form and water - insolubility of the product the bioavailability is negligible.

Handling

General ventilation is recommended. Avoid skin and eye contact.

Storage

Do not store with oxidizing agents. Keep container closed and store away from water or moisture.

Molykote® 111 Grease Safety Data

First Aid

SKIN:

No first aid should be needed.

INGESTION:

No first aid should be needed.

EYES:

No first aid should be needed.

INHALATION:

No first aid should be needed.

Fire

FLASH POINT: Above 101.1°C. (closed cup)

Explosive Properties: No

Suitable Extinguishing Media: Carbon Dioxide Foam, Dry Powder or fine water spray.

Water can be used to cool fire exposed containers.

Environment

No adverse effects are predicted.

Handling

General ventilation is recommended. Avoid eye contact.

Storage

Do not store with oxidizing agents. Keep container closed and store away from water or moisture.

Servicing the Tool

Service Kit

For an easy complete service, Avdel. offers the complete service kit below.

SERVICE KIT : 71210-99990		Spanners are specified in inches and across flats unless otherwise stated	
PART N°	DESCRIPTION	PART N°	DESCRIPTION
07900-00667	PISTON SLEEVE	07900-00012	$\frac{9}{16} \times \frac{5}{8}$ SPANNER
07900-00692	TRIGGER VALVE EXTRACTOR	07900-00015	$\frac{5}{8} \times \frac{11}{16}$ SPANNER
07900-00670	BULLET	07900-00686	PEG SPANNER
07900-00672	'T' SPANNER	07900-00677	SEAL EXTRACTOR
07900-00706	'T' SPANNER SPIGOT	07900-00698	STOP NUT
07900-00684	GUIDE TUBE	07900-00700	PRIMING PUMP
07900-00685	INSERTION ROD	07992-00020	GREASE - MOLYLITHIUM E.P.3753
07900-00351	3 MM ALLEN KEY	07992-00075	GREASE - MOLYKOTE® 55M
07900-00469	2.5 MM ALLEN KEY	07900-00755	GREASE - MOLYKOTE® 111
07900-00158	2 MM PIN PUNCH	07900-00850	PIN SPANNER
07900-00164	CIRCLIP PLIERS	07900-00898	VALVE HOOK
07900-00008	$\frac{7}{16} \times \frac{1}{2}$ SPANNER		

Maintenance

(Annually or every 500,000 cycles whichever is the soonest)

Annually or every 500,000 cycles the tool should be completely dismantled and new components should be used where worn, damaged or recommended. All 'O' rings and seals should be renewed and lubricated with Molykote® 55m grease for pneumatic sealing or Molykote® 111 for hydraulic sealing.

<p>IMPORTANT Read Safety Instructions on page 4. The employer is responsible for ensuring that tool maintenance instructions are given to the appropriate personnel. The operator should not be involved in maintenance or repair of the tool unless properly trained. The tool shall be examined regularly for damage and malfunction.</p>
--

The air line must be disconnected before any servicing or dismantling is attempted unless specifically instructed otherwise.

It is recommended that any dismantling operation be carried out in clean conditions.

Before proceeding with dismantling, empty the oil from the tool following the first three steps of the 'Priming Procedure' on page 29.

Prior to dismantling the tool it is necessary to remove the nose equipment. For instructions see the nose assemblies section, pages 8 to 12 or if a swivel head was fitted pages 14 to 16.

For a complete service of the tool, we advise that you proceed with dismantling of sub-assemblies in the order shown.

After any dismantling REMEMBER to prime the tool and to fit an appropriate nose assembly or swivel head.

Nose Equipment

- Unscrew Nose Casing **1** and Nose Tip.
- Remove the Nose Equipment Cartridge by sliding in the same plane to the Piston.
- Unscrew Jaw Housing **3** from the Jaw Spreader Housing 'T' **9** and remove Jaws **4**, Jaw Spreader **5**, Spring **7**, Buffer **6** and Detent Sleeve **10**.
- Inspect all components. Renew all damaged or worn parts.
- Clean all parts and apply MolyLithium Grease EP 3753 (07992-00020) to taper bore of Jaw Housing.
- Reassemble in reverse order to above.

Item numbers in **bold** refer to Nose Tip Tables on pages 9 and 10.

Servicing the Tool

Dismantling the Tool

Before dismantling the tool the oil must be emptied from it.

- With the air supply switched OFF at ON/OFF Valve Assembly **53** remove Bleed Screw **1** and Bonded Seal **5**.
- Insert tool over a suitable container, switch air supply ON and actuate tool.
- Oil will expel from bleed screw orifice into container.
- Switch air supply OFF after all oil is expelled.

Ensure the bleed screw orifice is facing away from the person performing this operation.

Head Assembly

- Twist and pull off Stem Collector Bottle Assembly **24**. See illustration on page 7.
- Remove Stop Plate Assembly **69** by unscrewing Screws **63** 2 off.
- Unscrew Retaining Nut **47**.
- Pull off Bottle Adaptor Assembly **31** together with 'O' Rings **19** and **27**.
- Remove End Cap Assembly **34** together with 'O' Rings **65** and Lip Seal **8**.
- Remove Spring **64**.
- Loosen Locknut **39** with a spanner* and unscrew Male 'T' Adaptor **40** together with 'O' Ring **11**.
- With draw Vacuum Sleeve **41**.
- Remove Locknut **39** together with 'O' Rings **18** and **14**.
- Push Head Piston **35** to the rear and out of Head Assembly **50** taking care not to damage the cylinder bore
- Using circlip pliers* remove Seal Retainer **42**. Push Lip Seal **7** and Bearing Tape **25** to the rear and out of Head Assembly **50** taking care not to damage the cylinder bore.
- Remove Seal Housing **48** and Lip Seal **2**.

Assemble in reverse order noting the following points:

- Place Lip Seal **7** onto the insertion rod* ensuring correct orientation. Locate the guide tube* into the head of the tool and push the insertion rod* with the seal in place through the guide tube*. Pull the insertion rod* out and then the guide tube*.
- The chamfered edge of Seal Retainer **42** must face forward with the gap at the bottom.
- After fitting Lip Seals **10**, **9**, 'O' Ring **17** and Bearing Tape **26** onto the Head Piston **35** ensuring correct orientation, lubricate the cylinder bore and place the piston sleeve* into the back of Head Assembly **50**. Slide the bullet* onto the threaded part of Head Piston **35** and push the piston with the seals through the piston sleeve* as far as it will go. Slide the bullet* off the piston and remove piston sleeve*.
- Male 'T' Adaptor **40** must be fully tightened onto Head Piston **35** before tightening Locknut **39** against it.
- Reprime in accordance with the instructions on page 29.

* Item included in the Service Kit. For complete list see page 20.

Item numbers in **bold** refer to the general assembly drawing and parts list on pages 26 and 27.

Servicing the Tool

Pneumatic Piston Assembly

- Remove 'ON/OFF' Valve Assembly **53**.
- Clamp the body of the inverted tool **ACROSS THE AIR INLET BOSSES** in a vice fitted with soft jaws.
- Pull off Rubber Boot **28**.
- Using the peg spanner* unscrew Base Cover **30**.
- Remove Cylinder Liner **36**.
- Remove Pneumatic Piston Assembly **49** together with 'O' Ring **57**, Lip Seal **56** and Guide Ring **58**.
- Engage the Seal Extractor* into Intensifier Seal Assembly **54** and withdraw Seal Assembly from intensifier tube of the Head Assembly **50**.

Assemble in reverse order to dismantling.

- Seals should be checked for damage and replaced as necessary. Lubricate pneumatic seals with Molykote® 55m and hydraulic seals with Molykote® 111.

Air Valve

Dismantling

- Remove Pneumatic Piston Assembly **49** as described above in Pneumatic Piston Assembly.
- Using Spanner (07900-00672), and Location Spigot (07900-00671). Unscrew Clamp Nut **38** and remove together with Clamp Plate **43** together with Transfer Tube Assembly **52**, Valve Rod Assembly **55** and 'O' Rings **13**.
- Remove tool from vice and separate Body **29** from Handle Assembly **70**. Remove 'O' Ring **16**.
- Push out the Valve Seat **33**, from the Body **29**, together with 'O' Rings **13**.
- Pull out Valve Spool Assembly **51** from Handle Assembly **70**. Remove 'O' Ring **6** from handle counterbore.

Assembly

Assemble in reverse order to Dismantling Instructions

- Seals should be checked for damage and replaced if necessary, lubricated with Molykote® 55m grease.
- Apply Loctite® 243 to Clamp Nut **38** and tighten to torque 11ftlb (14.91 Nm)

IMPORTANT

Check the tool against daily and weekly servicing.
Priming is ALWAYS necessary after the tool has been dismantled and prior to operating.

* Item included in the Service Kit. For complete list see page 20.
Item numbers in **bold** refer to the general assembly drawing and parts list on pages 26 and 27.

Servicing the Tool

Rotary Valve

Dismantling

- Using a 4mm pin punch (07900-00158) drive Trigger Pin **45** out and remove Trigger Assembly **32**.
- Remove Pneumatic Piston Assembly **49** as described in Pneumatic Piston Assembly page 22.
- Using Spanner (07900-00672), and Location Spigot (07900-00671), unscrew Clamp Nut **38** and remove together with Clamp Plate **43** together with Transfer Tube Assembly **52** and separate Body **29** from Handle Assembly **70**. Remove 'O' Rings **15** and **16**.
- Separate Head Assembly **50** from Handle Assembly **70**. NOTE ORIENTATION OF ROTARY VALVE **37**.
- Push out Rotary Valve **37** together with 'O' Rings **4**.

Assemble in reverse order to Dismantling Instructions noting the following:

- Seals should be checked for damage and replaced if necessary, lubricated with Molykote® 55m grease.
- Ensure Rotary Valve **37** is assembled in correct orientation to align valve pins with forks on the Trigger Assembly **32**. See illustration below.

Trigger

Dismantling

- Using a 4mm pin punch (07900-00158) drive Trigger Pin **45** out and remove Trigger Assembly **32**.
- Unscrew Trigger Valve **20** using trigger valve extractor (0900-00692).

Assemble in reverse order to Dismantling Instructions noting the following:

- When assembling Trigger Assembly **32** the trigger forks locate on the pins each side of the Rotary Valve **37**.
- Ensure Rotary Valve **37** is orientated correctly. See illustration below.

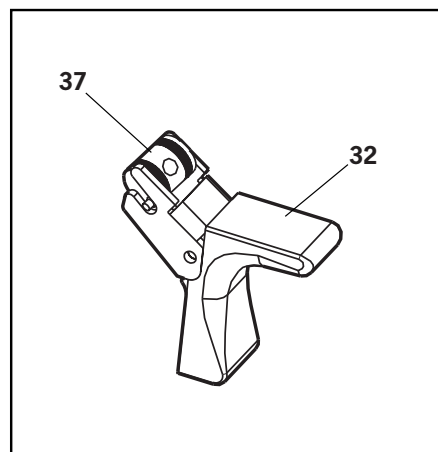

Item numbers in **bold** refer to the general assembly drawing and parts list on pages 26 and 27.

Servicing the Tool

Stop Plate Assembly (71213-03900)

Assembly (see illustration below)

- Place 'O' Ring **2** into the recess in Housing **5** retain in position using grease Molykote® 55m.
- Assemble 'O' Ring **4** onto Piston **1** and push assembly into Housing **5** making sure it is in as far as it will go.
- Position the slot in Piston **1** parallel to the step face in Housing **5**.
- Slide Plate Shut Off **3** into the assembled parts **1, 2, 4,** and **5**. Retain parts in place using grease Molykote® 55m.
- Place 'O' Ring **4** into the recess of Cover Plate **6** retain in position using grease Molykote® 55m.
- Place Spring **7** into position, locate using the recesses in both Plate Shut Off **3** and Bottle Adaptor Assembly **31***.
- Position the above assembled parts onto Bottle Adaptor Assembly **31***.
- Secure in position using two Screws **63***.

*see pages 26 and 27.

ITEM	DESCRIPTION
1	PISTON
2	'O' RING
3	PLATE SHUT OFF
4	'O' RING
5	HOUSING
6	COVER PLATE
7	SPRING

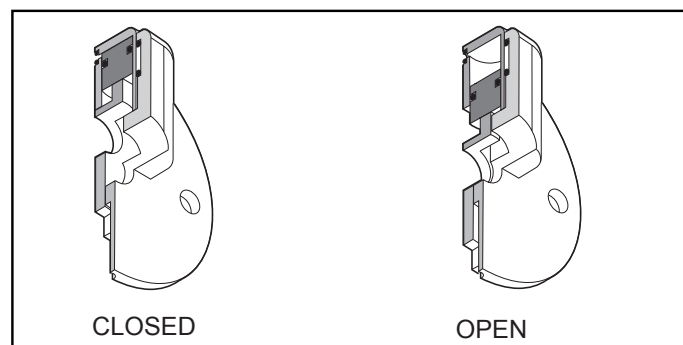
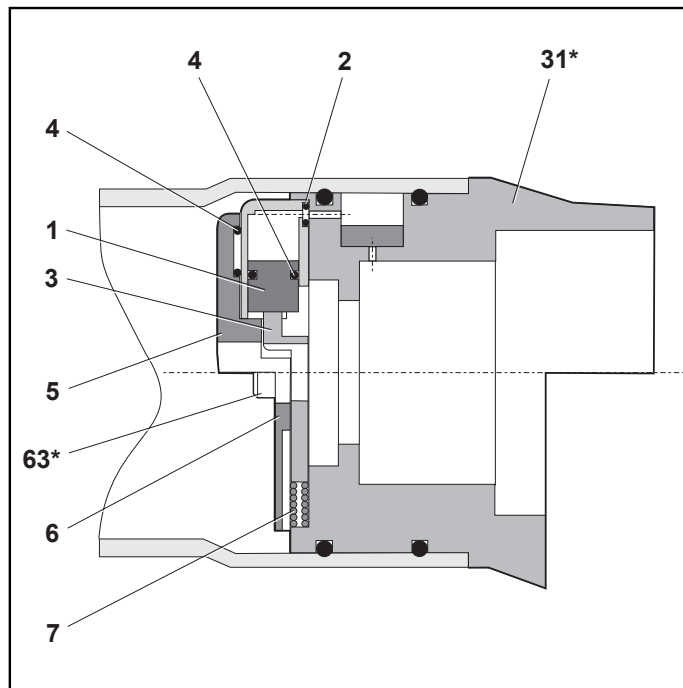

Notes

General Assembly of Base Tool 71203-02000

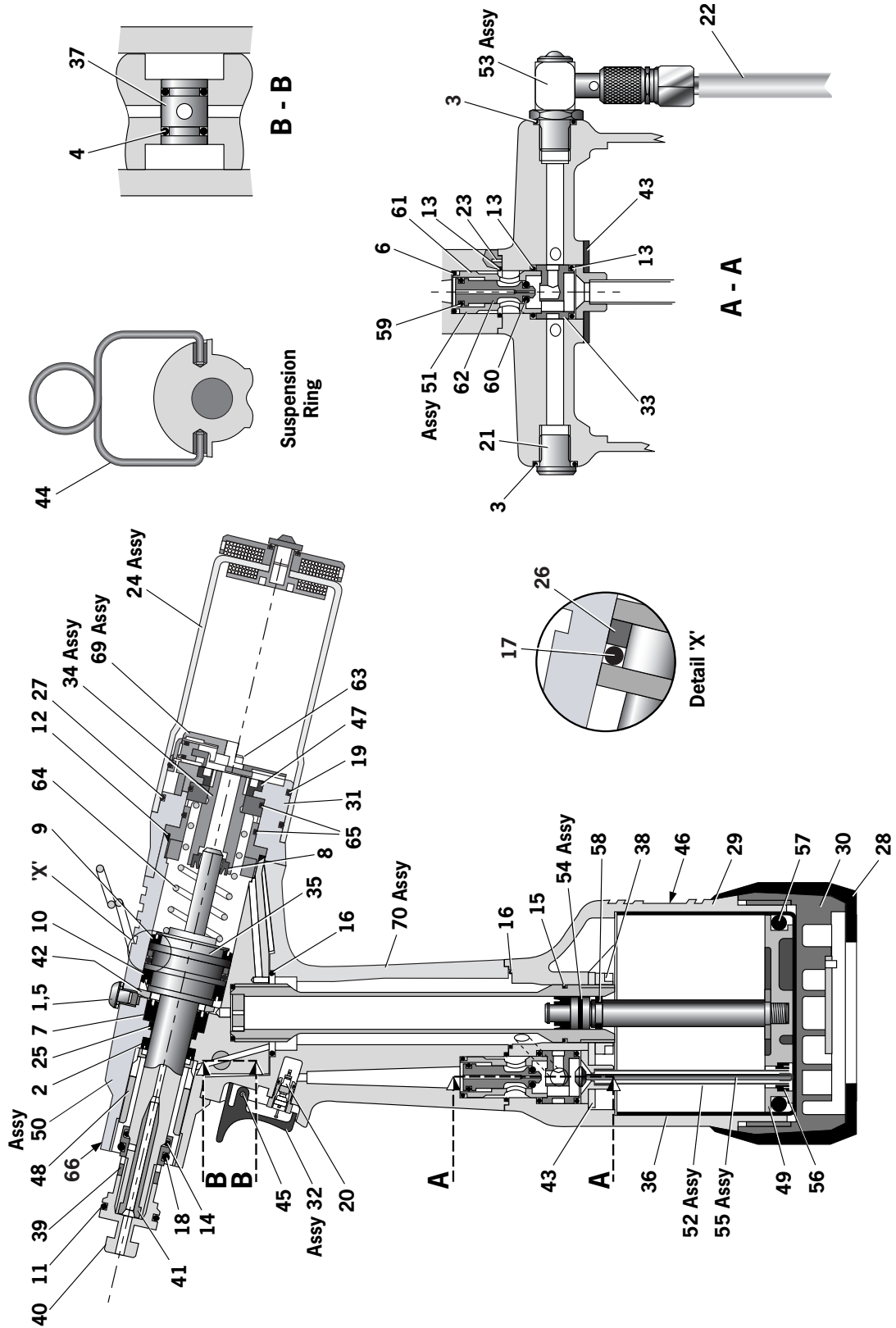

Parts List for 71203-02000

71203-02000 PARTS LIST							* These are minimum recommended levels of spares based on regular servicing		
ITEM	PART N°	DESCRIPTION	QTY	SPARES	ITEM	PART N°	DESCRIPTION	QTY	SPARES
01	07001-00405	M5x5 HEX SOCKET BUTTON HD SCREW	1		42	71210-02019	SEAL RETAINER	1	
02	07003-00333	LIP SEAL	1		43	71200-02021	CLAMP PLATE	1	
03	07003-00127	'O' RING	1		44	71210-02022	SUSPENSION RING	1	
04	07003-00189	'O' RING	2		45	71210-02024	TRIGGER PIN	1	
05	07003-00194	M5 BONDED SEAL	1		46	71203-02027	LABEL	1	
06	07003-00271	'O' RING	1		47	71213-02028	RETAINING NUT	1	
07	07003-00273	LIP SEAL	1		48	71210-02104	SEAL HOUSING	1	
08	07003-00274	LIP SEAL	1		49	71201-03200	PNEUMATIC PISTON ASSEMBLY (ITEMS 56 TO 58)	1	
09	07003-00275	LIP SEAL	1		50	71213-03320	HEAD ASSEMBLY	1	
10	07003-00341	LIP SEAL	1		51	71210-03400	VALVE SPOOL ASSEMBLY (ITEMS 59 TO 62)	2	
11	07003-00277	'O' RING	1		52	71200-03600	TRANSFER TUBE ASSEMBLY	2	
12	07003-00278	'O' RING	1		53	71210-03700	ON/OFF VALVE ASSEMBLY	1	
13	07003-00281	'O' RING	3		54	71210-03800	INTENSIFIER SEAL ASSEMBLY	1	
14	07003-00204	'O' RING	1		55	71200-03500	VALVE ROD ASSEMBLY	1	
15	07003-00287	'O' RING	1		56	07003-00300	LIP SEAL	1	
16	07003-00288	'O' RING	2		57	07003-00293	'O' RING	1	
17	07003-00342	'O' RING	1		58	71210-03205	GUIDE RING	1	
18	07003-00310	'O' RING	1		59	07003-00042	'O' RING	1	
19	07003-00415	'O' RING	1		60	07003-00268	'O' RING	1	
20	07005-00088	TRIGGER VALVE	1		61	71210-03401	VALVE BODY	1	
21	07005-01274	1/8" BSP PLUG	1		62	71210-03402	VALVE SPOOL	1	
22	07008-00010	6" FLEXIBLE HOSE	1		63	07001-00677	SCREW	2	
23	07007-00224	3mm DIAx10mm SPIROL PIN	2		64	07490-03002	SPRING	1	
24	71213-03800	STEM COLLECTOR BOTTLE ASSEMBLY	1		65	07003-00398	'O' RING (SPIGOT)	2	
25	71213-02021	BEARING TAPE - PISTON ROD	1		66	07007-01503	LABEL BOOK SYMBOL	1	
26	71213-02022	BEARING TAPE - PISTON	1		67	07900-00849	NOSE EQUIPMENT SPANNER (NOT SHOWN)	1	
27	07003-00416	'O' RING	1		68	07900-00843	TOOL INSTRUCTION MANUAL	1	
28	71200-02055	RUBBER BOOT	2		69	71213-03900	STOP PLATE ASSEMBLY	1	
29	71203-02003	BODY MACHINED	1		70	71213-02013	HANDLE ASSEMBLY	1	
30	71200-02006	BASE COVER	1						
31	71213-03000	BOTTLE ADAPTOR ASSEMBLY	1						
32	71213-02008	TRIGGER ASSEMBLY	1						
33	71210-02009	VALVE SEAT	1						
34	71213-02025	END CAP ASSEMBLY	1						
35	71213-02121	HEAD PISTON	1						
36	71200-02012	CYLINDER LINER	1						
37	71213-02012	ROTARY VALVE	1						
38	71210-02014	CLAMP NUT	1						
39	71210-02103	LOCKNUT	1						
40	71213-02020	MALE T ADAPTOR	1						
41	71210-02102	VACUUM SLEEVE	1						

Priming

Priming is ALWAYS necessary after the tool has been dismantled and prior to operating. It may also be necessary to restore the full stroke after considerable use, when the stroke may have been reduced and fasteners are not now being fully placed by one operation of the trigger.

Oil Details

The recommended oil for priming is Hyspin® VG32 available in 0.5 litre (part number 07992-00002) or one gallon containers (part number 07992-00006). Please see safety data below.

Hyspin® VG32 Oil Safety Data

First Aid

SKIN:

Wash thoroughly with soap and water as soon as possible. Casual contact requires no immediate attention. Short term contact requires no immediate attention.

INGESTION:

Seek medical attention immediately. DO NOT induce vomiting.

EYES:

Irrigate immediately with water for several minutes. Although NOT a primary irritant, minor irritation may occur following contact.

Fire

Flash point 232°C. Not classified as flammable.

Suitable extinguishing media: CO₂, dry powder, foam or water fog. DO NOT use water jets.

Environment

WASTE DISPOSAL: Through authorised contractor to a licensed site. May be incinerated. Used product may be sent for reclamation.

SPILLAGE: Prevent entry into drains, sewers and water courses. Soak up with absorbent material.

Handling

Wear eye protection, impervious gloves (e.g. of PVC) and a plastic apron. Use in well ventilated area.

Storage

No special precautions.

Priming Kit

To enable you to follow the priming procedure opposite, you will need to obtain a priming kit:

PRIMING KIT : 07900-00688	
PART N°	DESCRIPTION
07900-00351	3mm ALLEN KEY
07900-00700	PRIMING PUMP
07900-00224	4mm ALLEN KEY
07900-00698	STOP NUT
07900-00734	STOP NUT - MAXLOK®

Priming

Priming Procedure

I M P O R T A N T

**DISCONNECT THE TOOL FROM THE AIR SUPPLY OR SWITCH OFF AT VALVE SPOOL 62.
REMOVE NOSE ASSEMBLY OR SWIVEL HEAD COMPONENTS.**

All operations should be carried out on a clean bench, with clean hands in a clean area.

Ensure that the new oil is perfectly clean and free from air bubbles.

Care MUST be taken at all times, to ensure that no foreign matter enters the tool, or serious damage may result.

- Switch OFF air supply at ON/OFF Valve Assembly **53**.
- Remove all nose equipment. (see page 8)
- Remove Bleed Screw **1** and Bonded Seal **5**.
- Invert tool over suitable container, switch ON air supply at ON/OFF Valve Assembly **53** and actuate tool.
- Residual oil in the tools hydraulic system will empty through bleed screw orifice.

CARE SHALL BE TAKEN TO ENSURE THAT THE BLEED HOLE IS NOT DIRECTED TOWARDS THE OPERATOR OR OTHER PERSONNEL.

- Switch air supply OFF at ON/OFF Valve Assembly **53**.
- Screw priming pump (07900-00700) into bleed screw port, utilising Bonded Seal **5**.
- Actuate Priming Pump by pressing down and releasing several times until resistance is evident and the Head Piston starts to move rearward.

ENSURE PUMP IS KEPT 'SQUARE' TO BLEED SCREW PORT DURING PRIMING OPERATION TO PREVENT BREAKAGE OF BLEED NIPPLE ON PRIMING PUMP.

- Remove the priming pump, surplus oil will expel from bleed screw port.
- Replace the Bleed Screw **1** together with Bonded Seal **5**.
- Switch ON air supply at ON/OFF Valve Assembly **53**.
- Check that the stroke of the head piston reaches specification. If not repeat above procedure.
- Switch OFF air supply and refit nose equipment. (see page 8).

Item numbers in **bold** refer to the general assembly drawing and parts list on pages 26 and 27.

Fault Diagnosis

Symptom	Possible Cause	Remedy	Page Ref
More than one operation of the trigger needed to place fastener	Air leak	Tighten joints or replace components	
	Insufficient air pressure	Adjust air pressure to within specification	5
	Worn or broken jaws	Fit new jaws	8
	Low oil level or air in oil	Prime tool	28, 29
	Build up of dirt inside the nose assembly	Service nose assembly	8†
Tool will not grip stem of fastener	Worn or broken jaws	Fit new jaws	8, 9, 10, 12
	Build up of dirt inside the nose assembly	Service nose assembly	8
	Loose jaw housing	Tighten against locking ring	8
	Weak or broken spring in nose assembly	Fit new spring	8, 9, 10, 12
	Incorrect component in nose assembly	Identify and replace	9, 10, 12
Jaws will not release broken stem of fastener	Build up of dirt inside the nose assembly	Service nose assembly	8†
	Jaw housing, nose tip or nose casing not properly seated	Tighten nose assembly	9, 10, 12
	Weak or broken spring in nose assembly	Fit new spring	9, 10, 12
	Air or oil leak	Tighten joints or replace components	
	Low oil level or air present in oil	Prime tool	28-29
Cannot feed next fastener	Broken stems jammed inside tool	Empty stem collector	7
		Check jaw spreader is correct	9, 10, 12
		Adjust air pressure to within specification	5
Slow cycle	Low air pressure	Adjust air pressure to within specification	5
	Build up of dirt inside the nose assembly	Service nose assembly	8†
Tool fails to operate	No air pressure	Connect and adjust to within specification	5
	Damaged Trigger Valve 20	Replace	23
Fastener fails to break	Insufficient air pressure	Adjust air pressure to within specification	5
	Fastener outside tool capability	Use more powerful Genesis tool. Contact Avdel UK Limited.	
	Low oil level or air present in oil	Prime tool	28-29

* Pages 14 to 16 if a swivel head is used instead of a nose assembly.

† Page 16 if a swivel head is used instead of a nose assembly.

Item numbers in **bold** refer to the general assembly drawing and parts list on pages 26 and 27.

Other symptoms or failures should be reported to your local Avdel authorised distributor or repair centre.

Declaration of Conformity

We, Avdel UK Limited, Watchmead Industrial Estate, Welwyn Garden City, Herts, AL7 1LY
declare under our sole responsibility that the product:

Model nG1

Serial No.

to which this declaration relates is in conformity with the following standards:

EN ISO 12100 - parts 1 & 2	
BS EN ISO 8662 - part 6	BS EN ISO 11202
BS EN ISO 3744	BS EN 982
ISO EN 792 part 13 - 2000	BS EN 983

following the provisions of the Machine Directive 98/37/EC



A. Seewraj - Product Engineering Manager - Automation Tools

Date of issue

 **This box contains a power tool which is in conformity with Machines Directive 98/37/EC. The 'Declaration of Conformity' is contained within.**



An Acument™ Global Technologies Company

AUSTRALIA

Acument Australia Pty Ltd.

891 Wellington Road
Rowville, Victoria 3178
Tel: +61 3 9765 6400
Fax: +61 3 9765 6445
Email: info@acument.com.au

CANADA

Avdel Canada, a Division of Acument Canada Limited.

87 Disco Road
Rexdale
Ontario M9W 1M3
Tel: +1 416 679 0622
Fax: +1 416 679 0678
Email: infoAvdel-Canada@acument.com

CHINA

Acument China Ltd.

RM 1708, 17/F., Nanyang Plaza,
57 Hung To Rd., Kwun Tong
Hong Kong
Tel: +852 2950 0631
Fax: +852 2950 0022
Email: infochina@acument.com

FRANCE

Avdel France S.A.S.

33 bis, rue des Ardennes
BP4
75921 Paris Cedex 19
Tel: +33 (0) 1 4040 8000
Fax: +33 (0) 1 4208 2450
Email: AvdelFrance@acument.com

GERMANY

Avdel Deutschland GmbH

Klusriede 24
30851 Langenhagen
Tel: +49 (0) 511 7288 0
Fax: +49 (0) 511 7288 133
Email: AvdelDeutschland@acument.com

ITALY

Avdel Italia S.r.l.

Viale Lombardia 51/53
20047 Brugherio (MI)
Tel: +39 039 289911
Fax: +39 039 2873079
Email: vendite@acument.com

JAPAN

Acument Japan Kabushiki Kaisha

Center Minami SKY,
3-1 Chigasaki-Chuo, Tsuzuki-ku,
Yokohama-city, Kanagawa Prefecture
Japan 224-0032
Tel: +81 45 947 1200
Fax: +81 45 947 1205
Email: info@acument.co.jp

SINGAPORE

Acument Asia Pacific (Pte) Ltd.

#05-03/06 Techlink
31 Kaki Bukit Road 3
Singapore, 417818
Tel: +65 6840 7431
Fax: +65 6840 7409
Email: Tlim@acument.com

SOUTH KOREA

Acument Korea Ltd.

212-4, Suyang-Ri,
Silchon-Eup, Kwangju-City,
Kyunggi-Do, Korea, 464-874
Tel: +82 31 798 6340
Fax: +82 31 798 6342
Email: info@acumentkorea.com

SPAIN

Avdel Spain S.A.

C/ Puerto de la Morcuera, 14
Poligono Industrial Prado Overa
Ctra. de Toledo, km 7,8
28919 Leganés (Madrid)
Tel: +34 (0) 91 3416767
Fax: +34 (0) 91 3416740
Email: ventas@acument.com

UNITED KINGDOM

Avdel UK Limited

Pacific House
2 Swiftfields
Watchmead Industrial Estate
Welwyn Garden City
Hertfordshire
AL7 1LY
Tel: +44 (0) 1707 292000
Fax: +44 (0) 1707 292199
Email: enquiries@acument.com

USA

Avdel LLC

614 NC Highway 200 South
Stanfield,
North Carolina 28163
Tel: +1 704 888-7100
Fax: +1 704 888-0258
Email: infoAvdel-USA@acument.com

© Avdel UK Limited 2007

Manual No.	Issue	Change Note No.
07900-00843	A	06/124
	A2	06/536
	B	07/044
	B2	07/103
	B3	07/174

Avdel®, Avdel® SR, Avex®, Avibulb®, Avinox®, Avseal®, Bulbex®, Genesis®, Interlock®, MBC®, MBC®/LC, Monobolt®, Stavex®, T-Lok®, TLR® are trademarks of Avdel UK Limited.

www.avdel-global.com